

Features

- Pluggable, mounts between Power Hub and trunk cable
- Intrinsically safe (Ex ia), FISCO, Entity, DART Fieldbus, or general-purpose
- Optional diagnostics for wear
- Grounding of shield direct
- For FOUNDATION Fieldbus H1 and PROFIBUS PA
- Indication via LED and Advanced Diagnostics

Function

This fieldbus surge protector is in accordance with IEC 61158-2 and mounts on the trunk connector of FieldConnex® High-Density and Compact Power Hubs, protecting them. It directs power surges to earth via gas discharge tubes. It is certified intrinsically safe for circuits in hazardous areas up to Zone 0/Div. 1 and DART fieldbus. The surge protector is installed in Zone 1 ... 2 or Div. 1 ... 2.

Integrated diagnostics (option) continuously monitor wear caused by surges. The end of the useful life and thus the need for exchange is indicated in two ways: via an LED and in the control room via the FieldConnex® Advanced Diagnostics software.

Installation on the trunk connector is without additional wiring even as retrofit. A single grounding bar connects surge protectors mounted side by side to a common grounding point.

Assembly



Connection

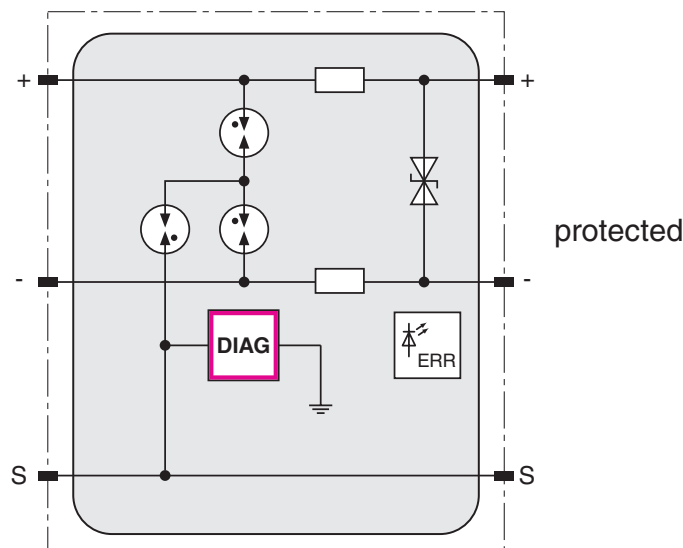

Release date 2016-11-22 09:52 Date of issue 2016-11-22 t157372_eng.xml

General specifications		
Design / Mounting		Cabinet installation
Fieldbus interface		
Self current consumption		≤ 6 mA (for version TPH-LBF-IA1.36.DE.1) , ≤ 0 mA (for version TPH-LBF-IA1.36.DE.0)
Indicators/operating means		
LED ERR		green flashing: status OK , red flashing: maintenance required , (for version TPH-LBF-IA1.36.DE.1)
Electrical specifications		
Rated voltage	U _r	36 V
Rated current	I _r	600 mA
Voltage protection level	U _p	
Line/Line		≤ 50 V category B2 10/700μsec , 25 A ≤ 52 V category C1 8/20μsec , 300 A ≤ 55 V category C2 8/20μsec , 5 kA ≤ 46 V category C3 1kV/μsec , 10 A
Line/Earth		≤ 1060 V category B2 10/700μsec , 50 A per line ≤ 800 V category C1 8/20μsec , 300 A per line ≤ 1450 V category C2 8/20μsec , 5 kA per line ≤ 1300 V category C3 1kV/μsec , 50 A per line ≤ 1080 V category D1 10/350μsec , 500 A per line
Reaction time	t _A	
Line/Line		≤ 1 ns
Line/Earth		≤ 100 ns
Overstressed fault mode		acc. IEC 61643-21 line inoperable mode 3
Series resistance in line		2 Ω +/- 5 %
Impulse durability		
Per line		5 kA category C2 8/20μsec
Directive conformity		
Electromagnetic compatibility		
Directive 2014/30/EU		EN 61326-1:2013
Standard conformity		
Electromagnetic compatibility		NAMUR NE 21
Degree of protection		IEC 60529
Fieldbus standard		IEC 61158-2
Climatic conditions		IEC 60721
Shock resistance		EN 60068-2-27
Vibration resistance		EN 60068-2-6
Surge protection		IEC 61643-21
Ambient conditions		
Ambient temperature		-40 ... 70 °C (-40 ... 158 °F)
Storage temperature		-40 ... 85 °C (-40 ... 185 °F)
Relative humidity		≤ 95 % non-condensing
Shock resistance		15 g 11 ms
Vibration resistance		1 g , 10 ... 150 Hz
Corrosion resistance		acc. to ISA-S71.04-1985, severity level G3
Mechanical specifications		
Connection type		screw terminals
Core cross-section		flexible wire 2.5 mm ² solid wire ≤ 4 mm ²
Housing material		Polyamide PA 6.6
Degree of protection		IP20
Mass		45 g
Grounding		M4 screw and external grounding rail
Data for application in connection with hazardous areas		
EU-Type Examination Certificate		SIRA 12 ATEX 2128X
Marking		⊕ II 1G Ex ia IIC T4
Voltage	U _i	24 V
Current	I _i	500 mA
Internal capacitance	C _i	2 nF
Internal inductance	L _i	0.1 μH
Certificate		SIRA 12 ATEX 4176X
Marking		⊕ II 3G Ex nAc IIC T4 , ⊕ II 3G Ex ic IIC T4 Class I and II, Division 1, Group C - G
Voltage	U _i	33 V
Current	I _i	600 mA
Internal capacitance	C _i	2 nF

Release date 2016-11-22 09:52 Date of issue 2016-11-22 t157372_eng.xml

Directive conformity	
Directive 2014/34/EU	EN 60079-0:2012 , EN 60079-11:2012 , EN 60079-15:2010 , EN 60079-26:2007
Supplementary information FISCO field device	
International approvals	
CSA approval	CoC 2595441
Control drawing	116-0365
Approved for	Class I, Division 1, Groups A, B, C, D T4 Class I, Zone 1, Ex ia IIC T4 Class I, Zone 2, Ex ic IIC T4 Class I, Zone 0, AEx ia IIC T4 Class I, Zone 2, AEx ic IIC T4 Class I, Division 2, Groups A, B, C, D T4 Class I, Zone 2, Ex nL IIC T4 Class I, Zone 2, Ex na IIC T4 Class I, Zone 2, AEx nAc IIC T4
IECEX approval	IECEX SIR 12.0051X
Approved for	Ex ia IIC T4
General information	
Supplementary information	Statement of Conformity, Declaration of Conformity, Attestation of Conformity and instructions have to be observed where applicable. For information see

Versions

Type	Description
TPH-LBF-IA1.36.DE.0	Fieldbus Surge Protector without diagnosis
TPH-LBF-IA1.36.DE.1	Fieldbus Surge Protector with diagnosis

Dimensions

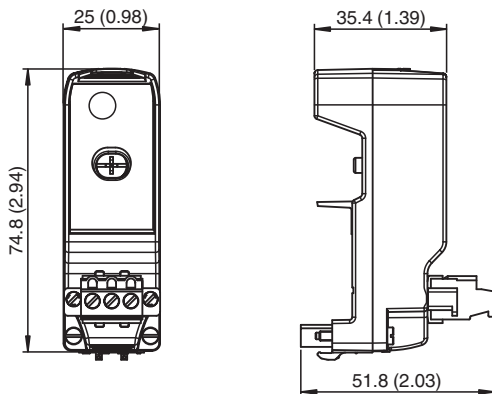

Dimensions in mm (in)

Accessories

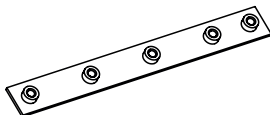

Grounding rail ACC-LBF-EB.4
for High-Density Fieldbus Power Hubs, type code MBHD*

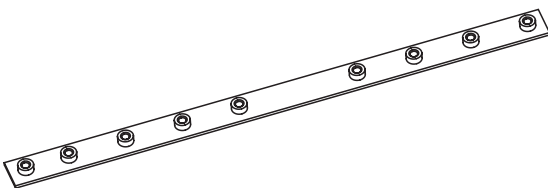

Grounding rail ACC-LBF-EB.8
for Compact Fieldbus Power Hubs, type code MBHC*

Release date 2016-11-22 09:52 Date of issue 2016-11-22 t157372_eng.xml